

LIVING SHORELINES:

A NATURAL APPROACH TO EROSION CONTROL



Introduction, Guidance, and Case Studies



The Galveston Bay Foundation (GBF) is a 501(c)(3) non-profit organization established in 1987 under the laws of the State of Texas. The Foundation's strength is that it involves a true cross-section of Bay interests to address issues and concerns related to Galveston Bay. It is managed by a strong Board of Trustees whose members represent sport and commercial fishing groups, government agencies, recreational users, environmental groups, shipping, development, and business interests. The mission of the Foundation is to preserve, protect, and enhance the natural resources of the Galveston Bay estuarine system and its tributaries for present users and for posterity. Its programs in advocacy, conservation, education, and research strive to ensure that Galveston Bay remains a beautiful and productive place for generations to come.

Galveston Bay Foundation
17330 Highway 3
Webster, TX 77598
Phone: 281-332-3381
Fax: 281-332-3153
www.galvbay.org

OUR SPONSORS

The Galveston Bay Foundation would like to thank the following sponsors for making this Living Shorelines document possible:



Table of Contents

| | |
|---|-----------|
| <i>OUR SPONSORS</i> | 1 |
| <i>LIVING SHORELINES: A NATURAL APPROACH TO EROSION CONTROL AND PREVENTION</i> | 4 |
| Introduction | 4 |
| What are Living Shorelines? | 5 |
| <i>LIVING SHORELINES DESIGN GUIDELINES</i> | 6 |
| Site Assessment | 6 |
| Project Design | 7 |
| Plant Selection..... | 7 |
| Timing..... | 9 |
| Permitting..... | 10 |
| Costs..... | 12 |
| <i>Example Methods and Case Studies</i> | 14 |
| Permanent Installations | 14 |
| A. Offshore Rock or Concrete | 14 |
| B. Reef Domes | 20 |
| C. Vinyl Sheetpile | 21 |
| D. Shoreline Grading | 23 |
| Temporary Wave breaks | 25 |
| A. Erosion Control Fencing | 25 |
| B. Coir Logs..... | 27 |
| <i>Conclusion</i> | 28 |
| <i>STATE AND FEDERAL AGENCIES</i> | 29 |
| <i>NOTES AND CALCULATIONS</i> | 31 |

Tables and Figures

| | |
|---|----|
| Figure 1. Planting diagram showing ideal plant spacing behind a wave break | 8 |
| Figure 2. Living Shoreline, Galveston Island | 9 |
| Figure 3. Permit Service Center flow chart, Amy Gohres, Weeks Bay Foundation..... | 11 |
| Figure 4. Living Shoreline, Galveston Island | 13 |
| Figure 5. BEFORE: Heavily eroded bluff shoreline suitable for construction of an offshore wave break..... | 14 |
| Figure 6. Pyramid vs. single stacking of sacrete in reference to mean high and mean low tide | 15 |
| Figure 7. Gaps in the breakwater allow for flow of nutrients and organics | 15 |
| Figure 8. Standard drawing showing a 10:1 slope | 16 |
| Figure 9. Dimensions of example 300' breakwater | 17 |
| Figure 10. Dimensions of fill material behind example breakwater..... | 17 |
| Figure 11. DURING: Planting in constructed fill area behind rock breakwater at Asher site..... | 18 |
| Figure 12. AFTER: Asher shoreline six months after planting behind rock breakwater | 19 |
| Figure 13. Reef domes installed at Sweetwater (left), encrusted with oysters (right)..... | 20 |
| Figure 14. DURING: Vinyl sheetpile installation | 21 |
| Figure 15. AFTER: Canal planting..... | 22 |
| Figure 16. BEFORE: Scarborough shoreline before grading and planting | 23 |
| Figure 17. AFTER: Scarborough shoreline six months after planting | 24 |
| Figure 18. Double-row erosion control fencing | 25 |
| Figure 19. Planting behind erosion control fence | 26 |
| Figure 20. Staked coir logs..... | 27 |
| Figure 21. Sunset on a Living Shoreline property | 28 |
| | |
| Table 1. Some common beneficial plants for low salinity environments | 8 |
| Table 2. Pricing guidelines: Shoreline armoring | 12 |
| Table 3. Pricing guidelines: Offshore/nearshore breakwater materials | 12 |
| Table 4. Pricing guidelines: Plants | 13 |
| Table 5. Estimated material needs for constructing an example breakwater | 17 |
| Table 6. Estimated material needs for fill behind example breakwater | 17 |

LIVING SHORELINES: A NATURAL APPROACH TO EROSION CONTROL AND PREVENTION

Introduction

A common concern of many landowners with shoreline property is erosion. A common response to erosion is “armoring”: the installation of bulkheads, rip-rap, or other hard structures directly onshore to stop erosion and protect property. These shoreline protection methods, particularly bulkheads, can actually increase erosion on adjacent properties and in front of the structure itself. Wave energy from wind, boat wakes, and storm events is reflected back from the armored shoreline causing scouring in front of, and increased erosion on each side of, the bulkhead or armored area. Bulkheads are prone to undercutting and structural failure requiring costly periodic maintenance and eventual replacement. Additionally, bulkheads and other hard structures placed directly onshore often eliminate or reduce access to valuable shoreline marsh and other riparian habitats. Shoreline hardening separates uplands from lowlands and causes the loss of important vegetated shallows as the area in front of the armoring is typically converted to open water. These intertidal marshes are important habitat for many wildlife species including birds and economically valuable fisheries species.

Since the 1950s, Texas estuarine (saltwater) wetlands have decreased approximately 9.5 percent, or roughly 59,600 acres. This is an average net loss of 1,600 acres per year.¹ The Galveston Bay system has lost over 20 percent of its tidal marshes since the 1940s.² Some areas, such as the bay side of Galveston Island, have been hit even harder with marsh losses upwards of 80 percent.³ In part, these losses can be attributed to subsidence which drowns the marshes as the water levels become too deep too rapidly for the marsh grasses to survive. The loss of soil-stabilizing vegetation makes the shoreline more vulnerable to erosion. The loss of vegetation exacerbates the negative effects of wind driven waves and boat wakes. In this way, marsh and shoreline are rapidly converted to open water. For these and other reasons, landowners face a constant battle to protect their property from loss due to erosion.

¹ Moulton, D.W. et al, “Texas Coastal Wetlands: Status and Trends, Mid-1950s to Early 1990s” 1997, USFWS, 17 October 2000 < <http://library.fws.gov/Wetlands/TexasWetlands.pdf>>

² The State of the Bay- A Characterization of the Galveston Bay Ecosystem, 2nd Ed. Galveston Bay Estuary Program Publication GBEP T-7. Lester and Gonzalez, Eds., 2002, 162 pages.

³Galveston Bay Estuary Program Publication GBNEP-49, The Galveston Bay Plan: The Comprehensive Conservation and Management Plan for the Galveston Bay System, 1994, 457 pages

What are Living Shorelines?

Innovative shoreline protection methods have been implemented within the Galveston Bay estuary system in an attempt to deal with shoreline erosion by mimicking natural coastal processes through the strategic placement of plants, stone, fill, and other structural and organic materials. Restoration specialists at some public lands, such as those near Anahuac and Brazoria National Wildlife Refuges, have built wave break structures from shell and/or rip-rap just offshore rather than directly onshore. Not only do these structures act as wave breaks, robbing the waves of their energy, they cause sediment-laden waves to deposit materials landward of the wave break. This process can build up sediment raising the elevation behind the wave break sufficiently to support marsh grasses without the need for extra fill-dirt. Many times, the wave break itself becomes encrusted with oysters and other crustaceans creating an artificial reef.

Local private landowners have incorporated smaller versions of the above projects and other techniques to stabilize their shorelines. Landowners are even creating projects incorporating these principles and techniques along canals or in front of existing armoring. This allows them to design a shoreline that incorporates environmental benefits, prolongs the life of their bulkhead, reduces long term maintenance and replacement costs, and protects their property from erosion. In addition to these important features, the end result is a shoreline that is functional as well as aesthetically appealing, often creating a lush green band of vegetation or a winding reef that follows the shoreline. Birds and fish are attracted to the restored areas, providing recreational opportunities and enjoyment for the landowner.

Living Shorelines are shoreline management options that provide erosion control while working with nature to restore, create or protect valuable habitat. As opposed to bulkheads or armoring, **Living Shorelines** are designed to allow natural coastal processes to take place by allowing the movement of organics in and out of the marsh; absorbing wave energy from wind, boats, and storm events; and filtering pollutants from runoff. In addition, they create and/or maintain vital habitat for economically and ecologically important fish and shellfish, and they provide nesting and foraging areas for resident and migratory birds. They can be built in front of bulkheads or armoring providing additional protection to existing structures while restoring shoreline habitat. **Living Shorelines** help protect landowner investments while enhancing the ecological value of the property. They are often less expensive than traditional shoreline armoring methods, and in some instances, grant funding is available to offset costs to landowners who are willing to protect and create habitat.

This document is intended to provide the reader with general guidelines for starting a **Living Shoreline** project through technical guidance and real examples. At the end of the document is a list of resources and agencies that are available to answer questions and help design a shoreline that meets landowner needs and plays an active role in protecting and restoring bay systems.

LIVING SHORELINES DESIGN GUIDELINES

When considering a **Living Shoreline** project the first question one must ask is, “Do I have an erosion problem?” If there is measurable land loss due to currents or waves and action is needed to stop or slow the loss of property, a **Living Shoreline** might be an option. If the shoreline is stable and stocked with quality, native high and low marsh plants – **STOP!** The first, and best, option in this situation is to do nothing. Local experts can help determine whether the shoreline is experiencing erosion and/or if it is already supporting beneficial plants that could be incorporated into the project design. (Agencies that can provide assistance are listed at the end of this document). If there is property loss or it is felt that action must be taken to prevent future loss, the following steps may be helpful. Depending on the reader’s background or level of knowledge, this document may be all that is needed to get started. However, it is more likely to be a starting place to provide information and to raise questions that will need to be asked when contacting the agencies for assistance.

Site Assessment

In order to determine what sort of shoreline enhancement is right for a property, one must first answer some questions about the particular shoreline and what factors are occurring:

- **Rate of erosion:** Can property loss be measured in inches or feet per year, or is the erosion noticeable over a span of many years? Rapid erosion might indicate the need for a more permanent solution such as a rock or concrete breakwater, whereas a temporary breakwater and dense planting might be enough to protect where erosion is minimal.
- **Type of shoreline:** Is the shoreline severely cut like a bluff? How high is the bluff? Is the bluff undercut? Alternatively, is the shoreline sloped but not supporting plants? The severity of the erosion can help one choose the right protective measures.
- **Erosional forces:** Is the property routinely subjected to waves generated by passing boats and/or jet-skis? If so, how often? Is the property subject to a prevailing wind that keeps relatively strong waves hitting the shore much of the time? Is the property in a protected area that gets occasional boat traffic or storm generated waves? Understanding the factors contributing to the erosion at the property will help determine how strong and/or permanent a wave break will be needed. Additionally, if the property is in an area frequently used by commercial or recreational boat traffic, navigational hazards and signage must be considered.
- **Water depth:** How deep is the water just offshore? Will the area behind the breakwater require filling to raise the elevation to support plants? How quickly does the depth increase? Does the bottom drop off steeply or slope gently

getting gradually deeper? These questions can help determine what steps will be necessary to achieve satisfactory plant growth.

- **Substrate:** Is the bottom offshore from the property sand, silt, clay, or shell? Is it hard or soft? Understanding the substrate can help determine what methods will or won't work in an area and how much settling of materials might occur after installation.
- **Salinity:** Is the water body fresh or salty? Salinity will determine what plants are chosen for a **Living Shoreline** installation.

Project Design

Once the questions above have been answered, a project plan can begin to take shape. By looking at the methods available, a landowner can begin to determine what is right for the property. In some instances, a landowner in a high wave energy environment with an eroded, steep, bluff shoreline may have to install a substantial offshore rock or concrete breakwater to trip the waves and calm the waters so that plants can establish and grow in a permanently protected area. In lower energy conditions, shoreline grading and planting might be all that is needed.

This document presents case studies from actual projects and is intended to be a guide to help landowners decide what options are best for their unique situations. The examples presented here are not exhaustive, and there are many combinations of methods that may be implemented to address erosion and habitat loss. The most important thing to remember is that **ONE SIZE DOES NOT FIT ALL.**

Plant Selection

In most areas around Galveston Bay, smooth cordgrass (*Spartina alterniflora*) is an appropriate choice for establishing vegetation along the shoreline. This aquatic plant's elaborate root structure helps hold the substrate intact to reduce erosion and provide habitat for marine organisms. *Spartina alterniflora* is a perennial grass that grows from extensive rhizomes. The plant grows in intermediate to saline marshes, often forming dense stands over broad areas. It is a major contributor of organic material to aquatic food chains. This plant is native to the Gulf coast.

In areas farther up rivers or bayous, lower salinity levels dictate that different plants be selected. There are many species of plants suited to this type of environment that can be selected based on habitat value, aesthetic appeal and availability.

Examples of some of these plants include but are not limited to the plants listed in the table below.

Table 1. Some common beneficial plants for low salinity environments

| Common name | Scientific name |
|-------------------|------------------------------|
| Swamp lily | <i>Crinum americanum</i> |
| Black needle rush | <i>Juncus roemerianus</i> |
| Palmetto | <i>Sabal minor</i> |
| Spider lily | <i>Hymenocallis liriosme</i> |
| Iris | <i>Iris virginica</i> |
| Cutgrass | <i>Zizaniopsis miliacea</i> |
| Bulltongue | <i>Sagittaria lancifolia</i> |

When planting in intertidal zones subject to changing water levels, sprigs (individual stems) are typically planted approximately three feet apart. To increase the chance of survival, the sprigs should be planted deeply enough that the roots are covered. Also, the stem must be secured by compacting the soil around the base of the stem to prevent the plant from washing out. In higher energy environments, it may be necessary to plant sprigs more densely, perhaps one or two feet apart. When planting behind a wave break, plants can be spaced three feet apart closer to shore decreasing to one foot apart directly behind the wave break. If plants are available and the budget allows, additional plants will increase vegetative cover and will help stabilize the shoreline more quickly.

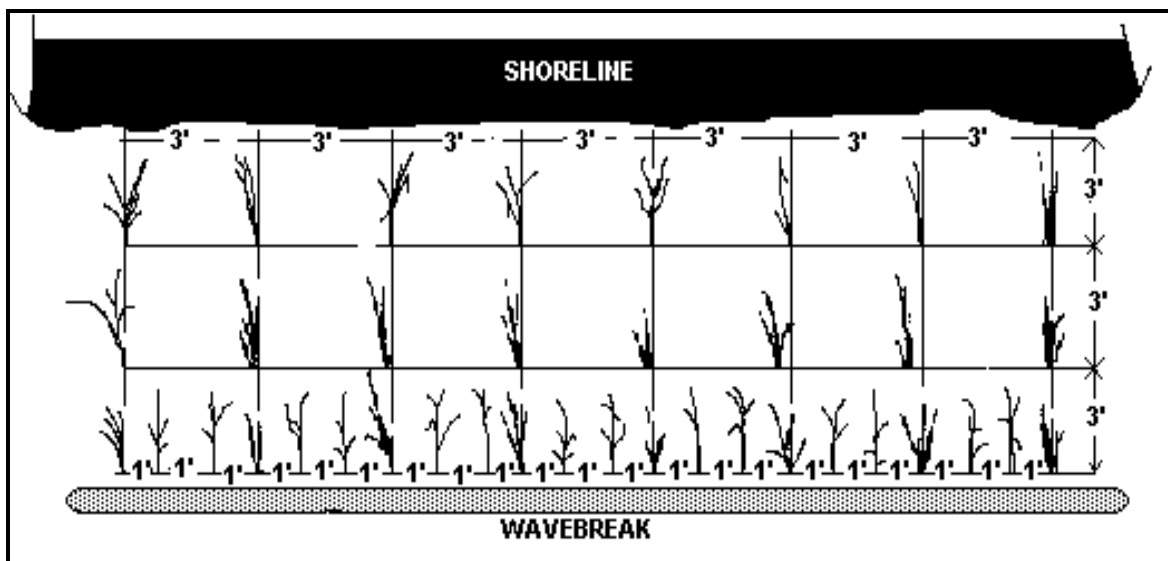

Figure 1. Planting diagram showing ideal plant spacing behind a wave break

Timing

If possible, it is best to begin construction on **Living Shoreline** projects during the winter months -- ideally November through January. Winter usually provides the lowest tides, making offshore construction easier. Also, beginning the project during the winter allows adequate time for any fill materials to settle before planting begins. The ideal months to begin planting are February through May. Planting during these months provides the plants a chance to become established during the growing season and allows the vegetation several months of growth before the following winter arrives. Obtaining the required construction and transplanting permits can take several months, so the application process should ideally be started in early summer; however, this is a guideline and not a rule.



Figure 2. Living Shoreline, Galveston Island

Permitting

Typically, when attempting shoreline work, there are four agencies that are part of the permitting process. These agencies must grant approval before work can commence. The U.S. Army Corps of Engineers (USACE) will determine whether the water body on which you are working is under their jurisdiction. If so, the landowner may be required to apply to the USACE for a permit under provisions of the Clean Water Act and/or the Rivers and Harbors Act. Certification from the Texas Commission on Environmental Quality (TCEQ) may also be required. During processing of the USACE permit application, the TCEQ will review the application to determine if the work will comply with state water quality standards. Since most submerged lands are considered “waters of the state” (i.e. they are the property of the State of Texas), a landowner may also have to apply for a state lease through the Texas General Land Office. An application must also be filed with the Texas Parks and Wildlife Department to gain approval to transplant vegetation into state waters. Finally, other agencies, including the National Ocean and Atmospheric Administration, the Environmental Protection Agency, and the U.S. Fish and Wildlife Service, will also review any proposed USACE applications to ensure environmental safeguards are taken into account during the permit review process.

While this may sound daunting at first, the agencies have worked together to simplify the process for landowners by forming the Permit Service Center (PSC). Established in 1999, the Permit Service Center is available to the public to assist with permitting on the Texas coast by acting as a clearinghouse for all permitting activities and offering information, guidance, and forms to those seeking to get their projects permitted. By consolidating forms and directing the forms to the responsible agencies, the PSC can be of great assistance in the permitting process. Landowners can also ask questions and seek guidance from state and federal agency experts through regular monthly pre-application meeting forums scheduled through the USACE. These meetings provide an informal setting through which applicants can obtain valuable advice prior to or during the formal permit application process.

Homeowner's Guide to Permitting Living Shorelines in Texas

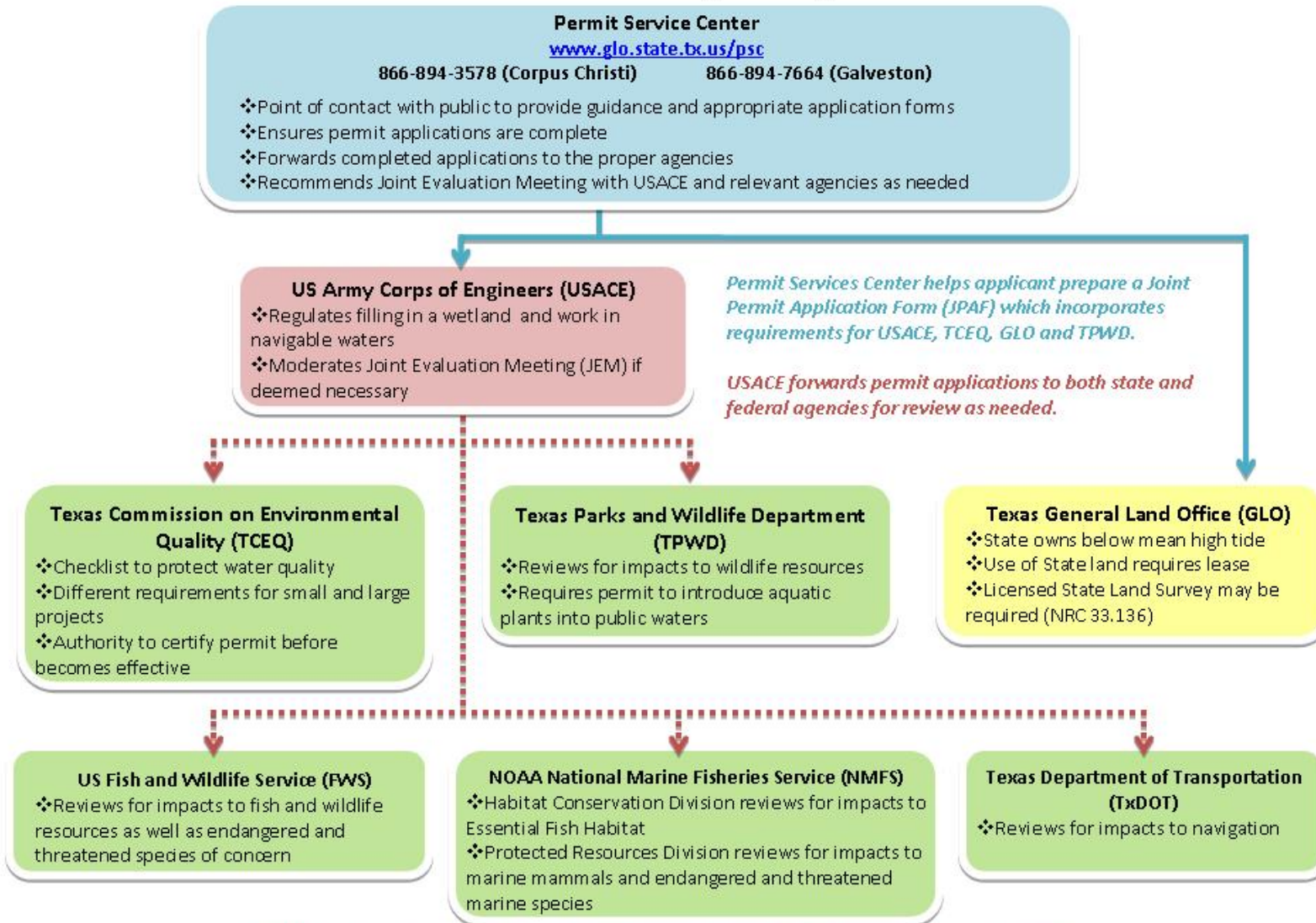

**Additional agencies and the general public may also be notified if deemed necessary by USACE.*

Figure 3. Permit Service Center flow chart, Amy Gohres, Weeks Bay Foundation

Costs

The current estimated pricing given in the tables below has been gathered from a variety of vendors and is presented for use as a comparison tool only. Pricing for individual projects will vary based on location, size, scope, materials and plants selected, and availability of materials.

Table 2. Pricing guidelines: Shoreline armoring

| Type | Unit | Installed Cost - \$/Unit (Labor and materials included) |
|-----------------------------------|-------------------------------|--|
| Vinyl bulkhead* | Linear Foot | \$125.00 - \$200.00 |
| Vinyl bulkhead* w/ toe protection | Linear Foot | \$210.00 - \$285.00 |
| Wooden bulkhead | Linear Foot | \$115.00 - \$180.00 |
| Wooden bulkhead w/ toe protection | Linear Foot | \$200.00 - \$265.00 |
| Concrete bulkhead | Linear Foot | \$100.00 - \$200.00 |
| Revetment | Cubic yard (yd ³) | \$25.00 - \$45.00 base cost \$120.00 - \$180.00 installed |

*(based on 4-8' height)

Miscellaneous Costs: Possible need for earthwork or backfill

Maintenance: Additional fill and vegetation over time, structural repair due to scour or storm damage

Table 3. Pricing guidelines: Offshore/nearshore breakwater materials

| Material | Unit | Base Cost \$/Unit | Installed Cost \$/Unit |
|--------------------------------|-------------------------------|--|---------------------------|
| Oyster shell | Yd ³ (loose shell) | \$50.00 - \$60.00/yd ³ | Varies |
| | Bag | \$5.00 without spat \$30.00 with spat | |
| Concrete bags | Bag | \$4.00 - \$6.00/bag | \$12.00 - \$16.00/LF |
| Limestone rock | Linear Foot | Varies | ~\$125.00 - \$200.00 |
| Reef domes | Linear foot | -- | \$44.00 (incl. delivery)* |
| Erosion control ("snow") fence | 100 feet | \$45.00 | Varies |
| Coir logs | 10' lengths | \$57.25 (incl. delivery) | Varies |

*Delivery charges can be impacted by number of domes ordered, distance driven, fuel prices and other factors and can vary greatly.

Maintenance: Possible need for additional shell or rock over time, possible repair after storms, removal of fencing

Table 4. Pricing guidelines: Plants

| Plant | Unit | Base Cost \$/Unit | Installed Cost \$/Unit |
|---|----------------------------------|--------------------------------|-----------------------------------|
| Smooth cordgrass <i>(Spartina alterniflora)</i> | Plug | \$1.25 | \$2.00 - \$3.00 |
| Marshhay cordgrass <i>(Spartina patens)</i> | Plug | \$1.25 | \$2.00 - \$3.00 |
| Mangrove | Gallon pot | \$5.00 | \$10.00 |
| Salt grass <i>(Distichlis spicata)</i> | 2" Plug 4" Plug | \$0.60 \$1.00 | \$2.00 \$3.00 |
| Bitter Panicum <i>(Panicum vaginatum)</i> | Node | \$1.00 | \$2.00 - \$3.00 |
| Freshwater species | Gallon pot | \$5.00 - \$6.00 | Varies |

Maintenance: Cost of additional plants/labor to replant any areas that don't take in the first planting



Figure 4. Living Shoreline, Galveston Island

EXAMPLE METHODS AND CASE STUDIES

The Galveston Bay Foundation and its agency partners have implemented various shoreline protection methods around the bay. These methods are chosen for and tailored to the specific needs of each individual site. Things to consider include but are not limited to: exposure to wave action caused by wind, boat wakes or other factors; water depth; existing shoreline conditions; and salinity. It is important to note that every site is unique and **one size does not fit all**.

Below are some of the methods that have worked at various locations around the Galveston Bay watershed, with example projects given as case studies to illustrate implementation. These methods can be expanded to work on any part of the Texas coast as long as local hydrological processes and native plant selections are taken into consideration.

Permanent Installations

A. Offshore Rock or Concrete

In higher wave energy areas, hard materials such as rock, rip-rap or bags of concrete (sacrete) can be used just offshore to create a wave break in front of an eroded shoreline.



Figure 5. **BEFORE:** Heavily eroded bluff shoreline suitable for construction of an offshore wave break

This method works equally well in front of existing shoreline armoring (e.g. an existing bulkhead) where habitat creation and additional protection are the goals. By installing a wave break and planting behind it, one can provide valuable cover and food for small fish, shrimp, and crabs as well as habitat for birds that are attracted to the food and shelter behind the wave break. The area behind the wave break may fill naturally or may be filled with materials to achieve elevations suitable for planting. In order to create conditions that will encourage natural filling and mimic natural marsh conditions, the breakwater height should fall between mean high and mean low tide. At high tide, waves should wash over the breakwater bringing in fresh nutrients and organics and dropping sediments. At low tide, water should be allowed to run out of the marsh to allow for flushing of the area. Additionally, the breakwater should be planned with gaps (a one foot break for every 50 feet of wave break is typical) to allow ingress and egress of marine resources. The gaps may be staggered or overlapping to slow the flow of water which may carry sediments out of the project area. Maintaining sediment behind the breakwater is key to project success.

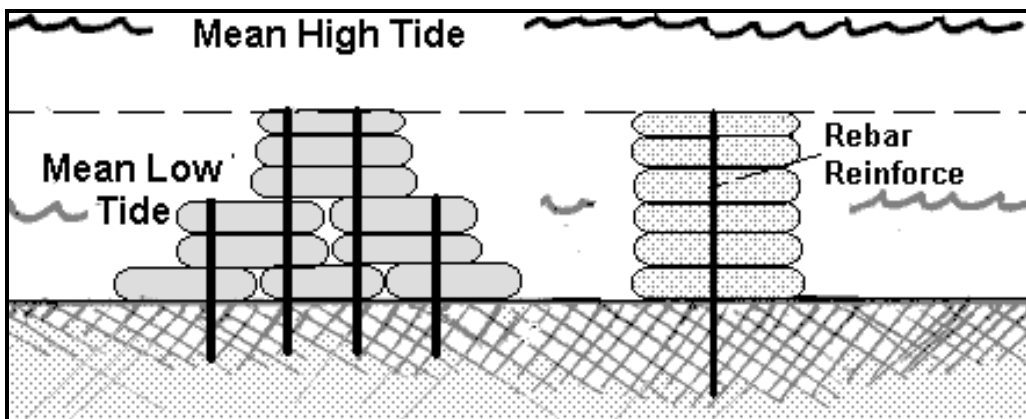

Figure 6. Pyramid vs. single stacking of sacrete in reference to mean high and mean low tide

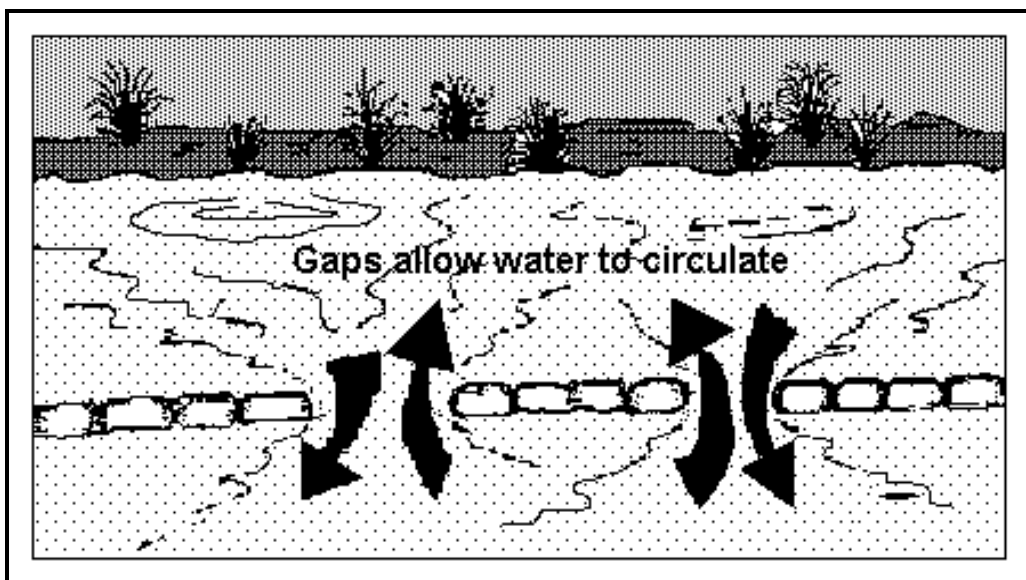

Figure 7. Gaps in the breakwater allow for flow of nutrients and organics

If rip-rap (broken concrete blocks) already exists along the present shoreline, all or part of it can be used to construct the wave break by moving and stacking it a short distance from and parallel to the existing shoreline. If rip-rap is not available, sacrete can be used. Sacrete can be purchased under the brand names QUIKRETE® or Sakrete®. The material is packaged in biodegradable 80-pound paper bags so it can be stacked offshore where it is needed. Salinity can impact the ability of the concrete to set, so one should check with the vendor to determine which product is right for each project. The bags must be abutted against each other to ensure that the fill materials placed behind the wave break do not wash out. The bags may also be stacked in staggered rows to prevent wash-out and further stabilize the wave break. Also, shell hash or oysters placed behind the breakwater can minimize sediment loss.

Three 80-pound sacrete bags stacked vertically provide approximately one foot of elevation, and seven bags laid end-to-end provide about five feet of length. If the height of the wave break is more than a foot or so, stacking the sacrete in a pyramid shape is suggested to ensure that the structure does not fall over. Also, consider stacking the materials with the pyramid method if wave energy is high. Sacrete breakwaters can be reinforced by driving rebar through the bags and into the substrate, strengthening the structure.

Once a breakwater is complete, the elevation of the area behind the breakwater must be raised to a sufficient level to support marsh plants. The filled area should slope from the mean high water mark to the breakwater. A 10:1 slope is generally acceptable, but this will vary from site to site depending on local conditions, e.g. the distance from the mean high water mark to the breakwater.

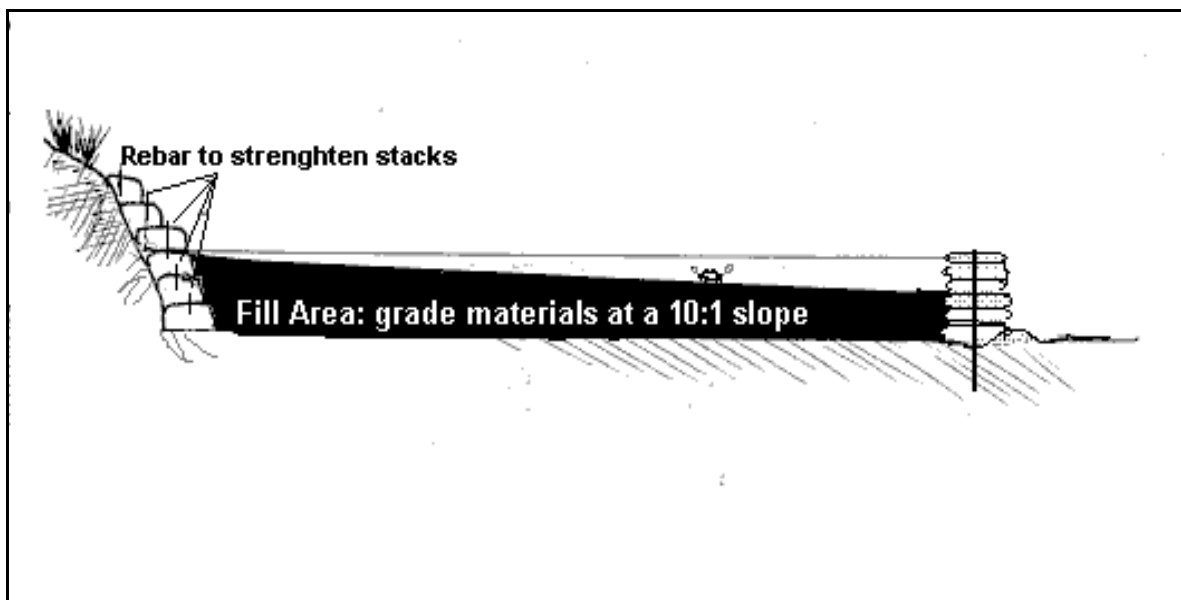

Figure 8. Standard drawing showing a 10:1 slope

Example: Diagrams and calculations for constructing a 300 foot long breakwater, 3 feet wide at the base, 30 feet from shore

Table 5. Estimated material needs for constructing an example breakwater

| Calculations for 300' Example Breakwater | |
|--|------------------------------------|
| Item | Size |
| Front Wall | $300' \times 3' = 900$ square feet |
| Sides | $3' \times 30' = 90$ square feet |
| Total | 990 square feet |
| Wave break calculations: | |
| 170 bags of material are needed for 100 square feet of barrier | |
| 990 square feet / 100 square feet = 9.9 | |
| 9.9×170 bags = $1,683$ bags of material | |

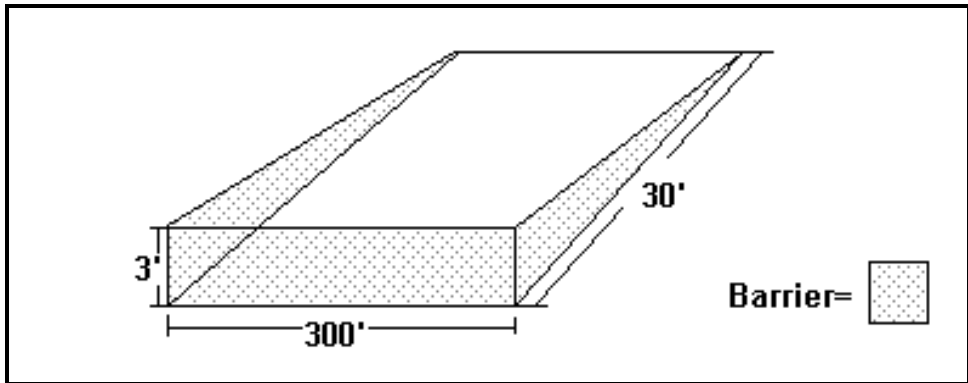

Figure 9. Dimensions of example 300' breakwater

Table 6. Estimated material needs for fill behind example breakwater

| Fill Materials for 300' Example Breakwater |
|---|
| Calculations: |
| $30' \times 2' \times 300' = 18,000$ cubic feet |
| $18,000$ cubic feet / 2 (half the square) = $9,000$ cubic feet |
| $9,000$ cubic feet / 27 (convert cubic feet to cubic yards) = 333 cubic yards |

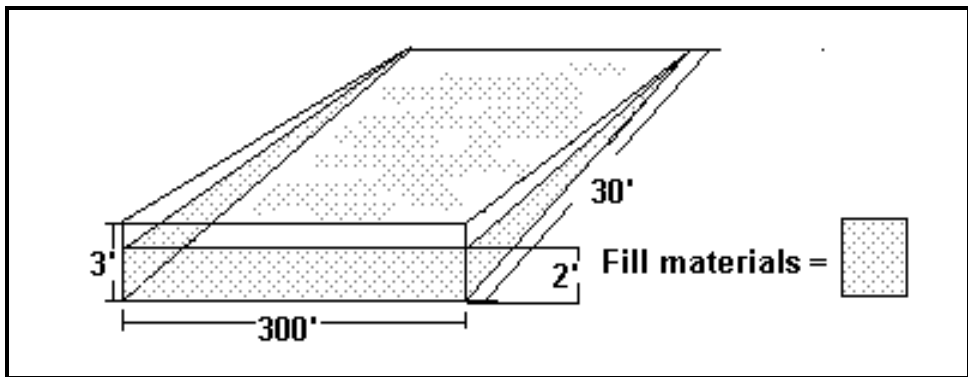

Figure 10. Dimensions of fill material behind example breakwater

Case Study: Asher Project

One of the Galveston Bay Foundation's early **Living Shoreline** projects involved the creation of a 450-foot rip-rap and sacrete breakwater that was constructed and backfilled to create approximately 4,000 square feet of tidal marsh along Dickinson Bayou in Galveston County, Texas. The bluff shoreline shown in Figure 5 above was graded to allow for more plantable area (Figure 11 below). A breakwater was constructed approximately 8-feet offshore, and the area between the breakwater and newly graded shoreline was filled with clean fill. The filled area was planted with *Spartina alterniflora*.

In addition to creating habitat, the project generated interest in the local community, serving as a prime example of an alternative method of shoreline protection that provides aquatic habitat while being significantly less expensive than traditional armoring.



Figure 11. DURING: Planting in constructed fill area behind rock breakwater at Asher site



Figure 12. AFTER: Asher shoreline six months after planting behind rock breakwater

B. Reef Domes

In some instances, landowners wish to specifically create oyster habitat in combination with their shoreline protection project. To achieve this goal, there are several routes that can be taken. In some instances, landowners can place old oyster shell or crushed concrete on open bottom offshore to provide a place for oyster larvae to attach and grow. Alternatively, reef domes can be used to encourage oyster colonization while also acting as a breakwater. Reef domes are patented hollow concrete dome-like structures used for shoreline protection and habitat creation. Reef domes placed offshore act to trip waves and calm waters near shore to allow for planting and shoreline stabilization. Because reef domes are large and heavy, barges or boats are often needed to move them from an onshore staging area to their offshore resting place. Galveston Bay Foundation or the agency resources listed at the end of this document can assist with determining whether reef domes would be suitable for specific projects. Once reef domes are installed, the area behind the domes can be allowed to fill naturally as waves drop sediment behind them or clean fill can be manually placed behind the domes.

Case Study: Sweetwater Property

Galveston Bay Foundation has placed over 1,000 feet of reef domes along the shore of its Sweetwater Property on Galveston Island. The property has approximately 3,500 feet of shoreline affected by severe erosion from wave energy that has resulted in the loss of fringing salt marsh habitat. At this property, reef domes were deployed both in single and double rows to allow for increased erosion control and sediment accretion.



Figure 13. Reef domes installed at Sweetwater (left), encrusted with oysters (right)

C. Vinyl Sheetpile

In areas where space is a concern, such as on a canal, one does not want to take up valuable planting area with rock or sacrete. In these cases, a plantable shelf can be created by driving vinyl sheetpile vertically into the substrate leaving some sticking up from the bottom to form the edge of the shelf. Just as with a rock or sacrete breakwater, the top of the vinyl sheetpile should fall between the mean high and mean low tide marks so that water will overtop the breakwater at high tide and leave it exposed at low tide.

Case Study: Alonso Project

Vinyl sheetpile has been employed successfully in the Lafitte's Cove canal subdivision on West Galveston Island. The property owners wished to create habitat in front of their existing bulkhead on the canal. Existing high marsh found on the property was incorporated into the final project design. In total, the project created approximately 2700 square feet of inter-tidal marsh along 180 feet of waterfront on a 150 foot wide canal. The amount of marsh created would have been significantly diminished had sacrete or rock been used as a breakwater. In this instance, a barge was used to bring in the sheetpile and the machinery used to install it. Fill material was dredged from the canal itself and deposited behind the sheetpile.



Figure 14. DURING: Vinyl sheetpile installation



Figure 15. AFTER: Canal planting

D. Shoreline Grading

In some instances, placing hard material offshore is not practical perhaps because it presents a hazard to navigation, or because the near shore bottom drops off steeply, or because of space limitations. One method that has been successful in such environments is grading the shoreline back from the waterline to maximize the suitable area for planting. By scraping back and gently sloping the shoreline, a larger area is made plantable.

Case Study: Scarborough Property

Located along a diversionary canal near Hitchcock, Texas, the Scarborough property offered a low wave energy environment on a relatively narrow water body. The near shore bottom dropped steeply leaving only a narrow band of ground suitable for planting between the bluff shoreline and the point where the water became too deep to support plants.



Figure 16. BEFORE: Scarborough shoreline before grading and planting

By grading the shoreline back from the waterline, the bluff was leveled out and the plantable area was widened toward the upland area. Pushing fill into the water was not feasible given the steep drop in the bottom just offshore. Smooth cordgrass was planted densely to increase its ability to take root and establish quickly. Because wave energy from boat wakes or wind driven waves is low in this area, no hard structure or even temporary fencing was deemed necessary.



Figure 17. AFTER: Scarborough shoreline six months after planting
Photo: Tom Scarborough

Temporary Wave breaks

A. Erosion Control Fencing

In many areas around Galveston Bay, subsidence due to the pumping out of groundwater is the main culprit in marsh loss. As the ground has sunk, marsh grasses have died. If other erosional forces are minimal, a temporary wave break such as erosion control fencing may be installed to temporarily cut down on wave action until plants installed behind the fence become established. Once the vegetation has taken hold and developed a strong root system, the fencing can be removed leaving behind a natural wave break of plants that will trap and hold additional sediments and filter impurities out of the water.

Case Study: Sullivan Project

The loss of marsh grass contributed to increased erosion and shoreline loss along this Trinity Bay property. To combat this, the property owner installed 955 linear feet of double row erosion control fencing and planted *Spartina alterniflora* behind it creating approximately 13,000 square feet of marsh. The fencing will be removed once the plants have established and grown dense enough to withstand the wind driven waves along his portion of the shore.



Figure 18. Double-row erosion control fencing



Figure 19. Planting behind erosion control fence

B. Coir Logs

Coir logs are constructed of interwoven coconut fibers that are bound together with biodegradable netting. Commercially produced coir logs come in various lengths and diameters. Coir logs are best used in low energy environments, as they are intended to biodegrade over time after plants have had a chance to become established. While the plants are growing and getting established, the coir logs provide a wave break to still the waters behind them. Plants can be planted into the coir logs themselves as well as behind them.

Coir logs will need to be secured to ensure that they are not dislodged by moving water.



Stakes can be driven through the coir log netting and then into the substrate to anchor them. The higher the wave energy, the more stakes are required to hold the coir logs in place. Coir logs should not be used in areas where wave energy is significant. Logs should not be secured in areas where they are submerged most of the time. Excessive wave energy can cause the material to fall and the log to fail. Coir logs are an inexpensive alternative that can easily be deployed by a landowner or small work group. Placing the logs parallel to the shoreline has shown success. However, when wave energy is more significant, it may work better to place the logs perpendicular to the shoreline. This technique has shown success and works similar to a mini-jetty. The logs are biodegradable, and it is anticipated that the vegetation will establish before the logs fail.

Figure 20. Staked coir logs

CONCLUSION

Whatever methods are chosen, a **Living Shoreline** can provide erosion control with the added benefits of water quality improvement, habitat creation or restoration, and increased aesthetic value, often for less than the cost of traditional shoreline armoring. By installing a **Living Shoreline**, property owners are adding to cumulative habitat benefits within a water body. Small incremental landowner projects, when added together and taken into account with larger scale restoration and protection projects in a geographic area, can add up to big watershed level changes. **Living Shorelines** are a viable, beneficial method for controlling shoreline erosion that allows coastal residents to play an important part in saving habitat in their own backyard for the benefit of future generations.



Figure 21. Sunset on a Living Shoreline property
Photo: Bob Moore

STATE AND FEDERAL AGENCIES

U.S. Army Corps of Engineers

Regulatory Branch, CESWG-CO-RE
U.S. Army Engineer District, Galveston
CESWG-PE-R
P.O. Box 1220
Galveston, TX 77551
Phone: 409-766-3930
Fax: 409-766-3931
<http://www.swg.usace.army.mil>

Texas General Land Office: Permit Service Centers

PO Box 1675
Galveston, Texas 77553-1675
Phone: 409-741-4057; 1-866-894-7664 (toll free)
Fax: 409-741-4010
<http://www.glo.state.tx.us/psc>

Texas A&M University-Corpus Christi
6300 Ocean Dr., NRC #2800, Unit 5841
Corpus Christi 78412-5841

Texas General Land Office – Field Office

11811 North D. St.
LaPorte, Texas 77571
Phone: 281-470-1191
Fax: 281-470-8071
<http://www.glo.state.tx.us>

Texas Commission on Environmental Quality

Watershed Management Division
P.O. Box 13087
Capitol Station
Austin, Texas 78711
<http://www.tceq.state.tx.us>

NOAA National Marine Fisheries Service

Habitat Conservation Division

4700 Avenue U

Galveston, TX 77551-5997

Phone: 409-766-3699

Fax: 409-766-3575

<http://sero.nmfs.noaa.gov/hcd/hcd.htm>

U.S. Fish and Wildlife Service

Clear Lake ES Field Office

17629 El Camino Real #211

Houston, TX 77058-3051

Phone: 281-286-8282

Natural Resource Conservation Service

7705 W. Bay Rd.

Baytown, Texas 77520

Phone: 281-383-4285

Fax: 281-383-4286

<http://www.nrcs.usda.gov/>

NOTES AND CALCULATIONS